

# Deichsel

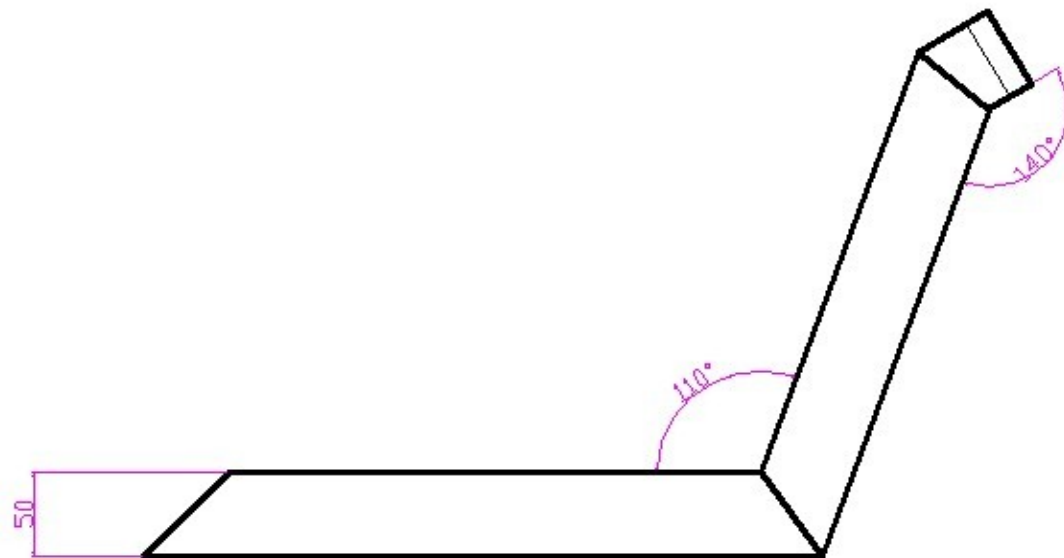

2x vorderer  
Seitenrohrflansch  
(Blechstärke 10mm)

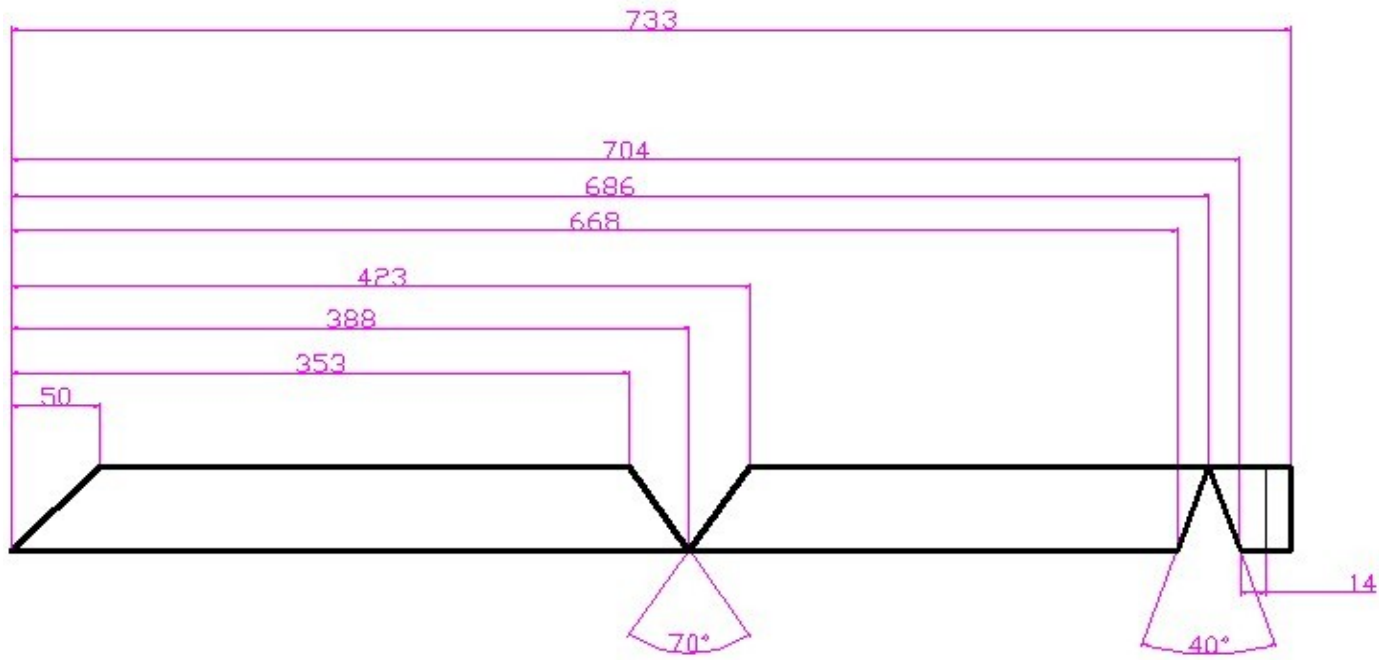
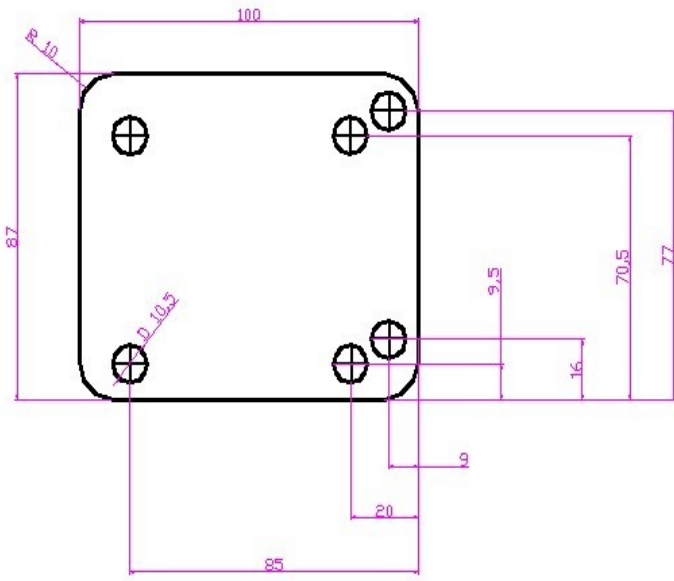

2x Hinterachs-  
flansche (Blechstärke  
8mm)

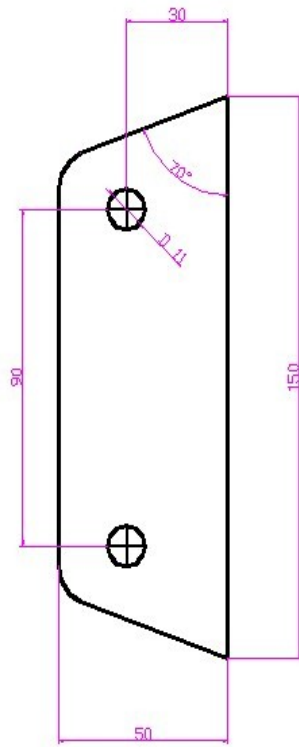

2x hintere Seitenrohr-  
flansche (Blechstärke  
8mm)

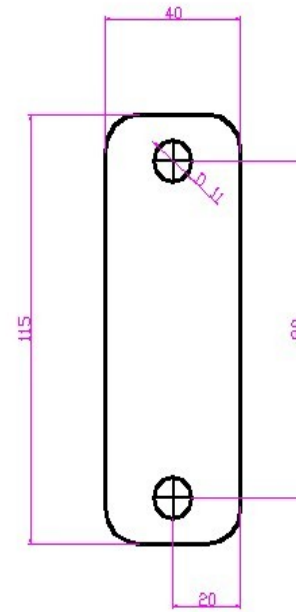

# Vorderachse mit Hülse zum Zentrieren

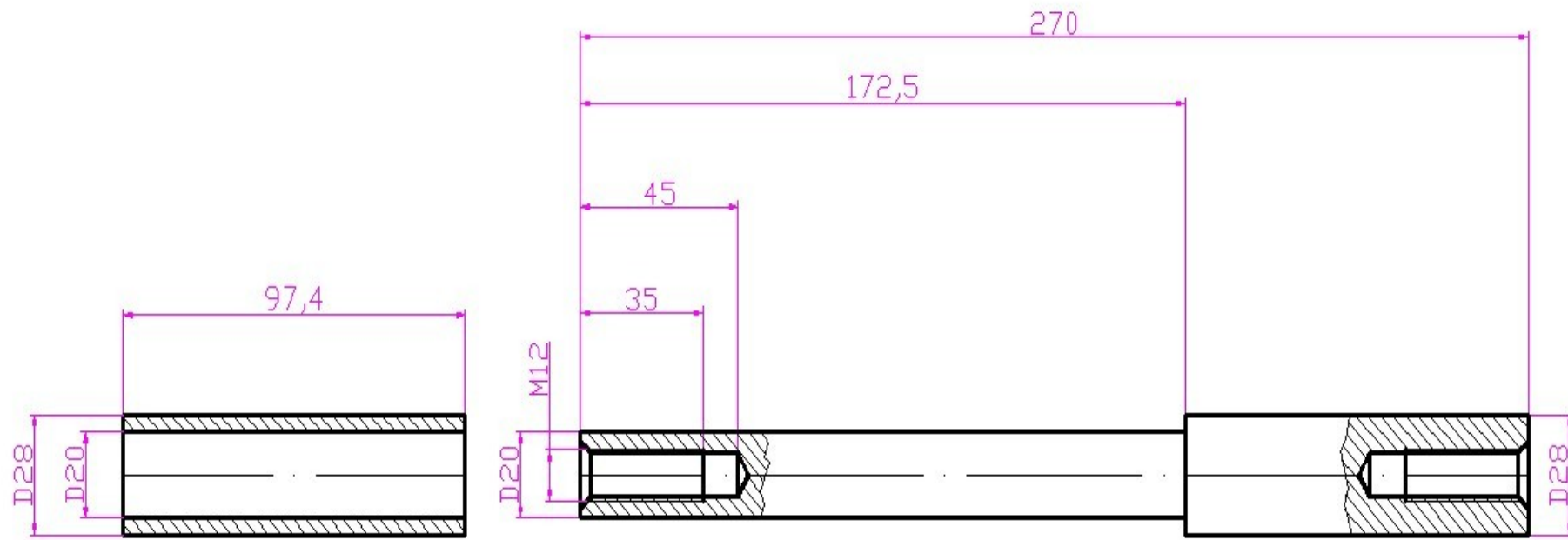

2x Fußraste (Blechstärke 8mm und Rohr 25 x 2)

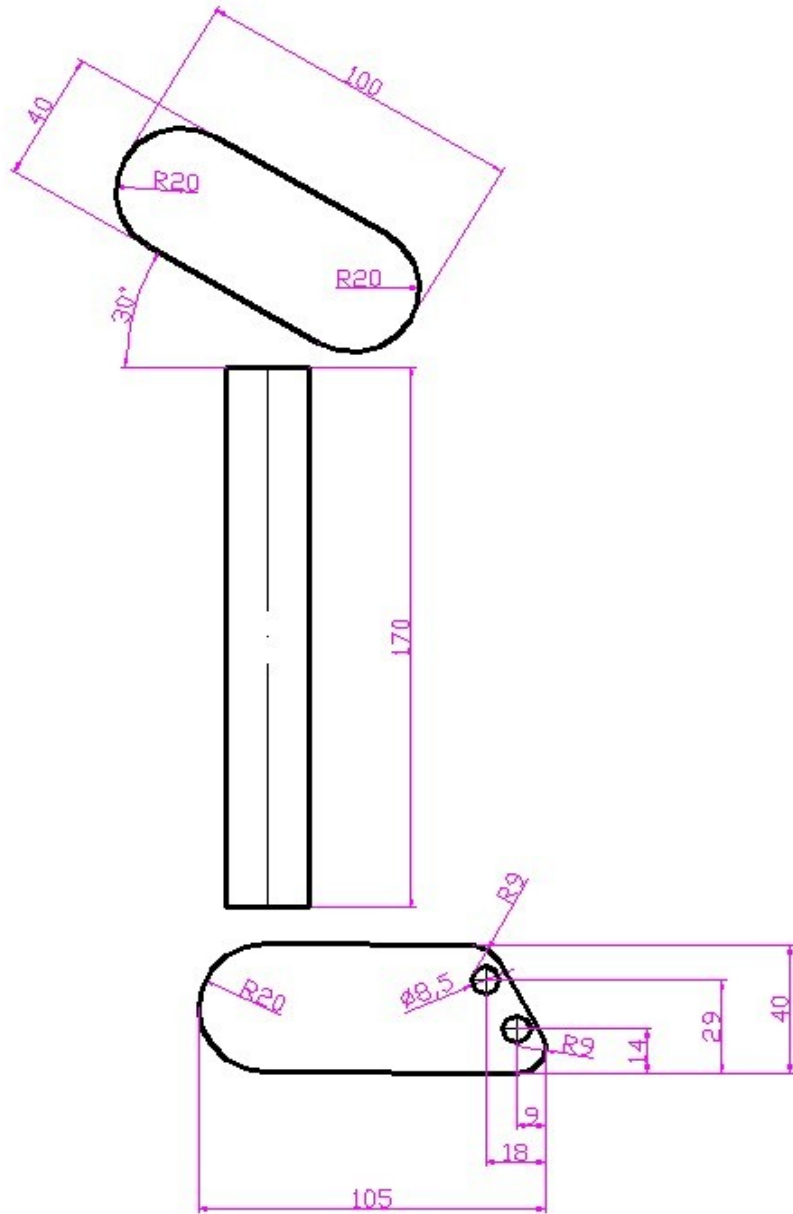

Lenkkopf mit Bolzen und PTFE-Lagerbuchsen

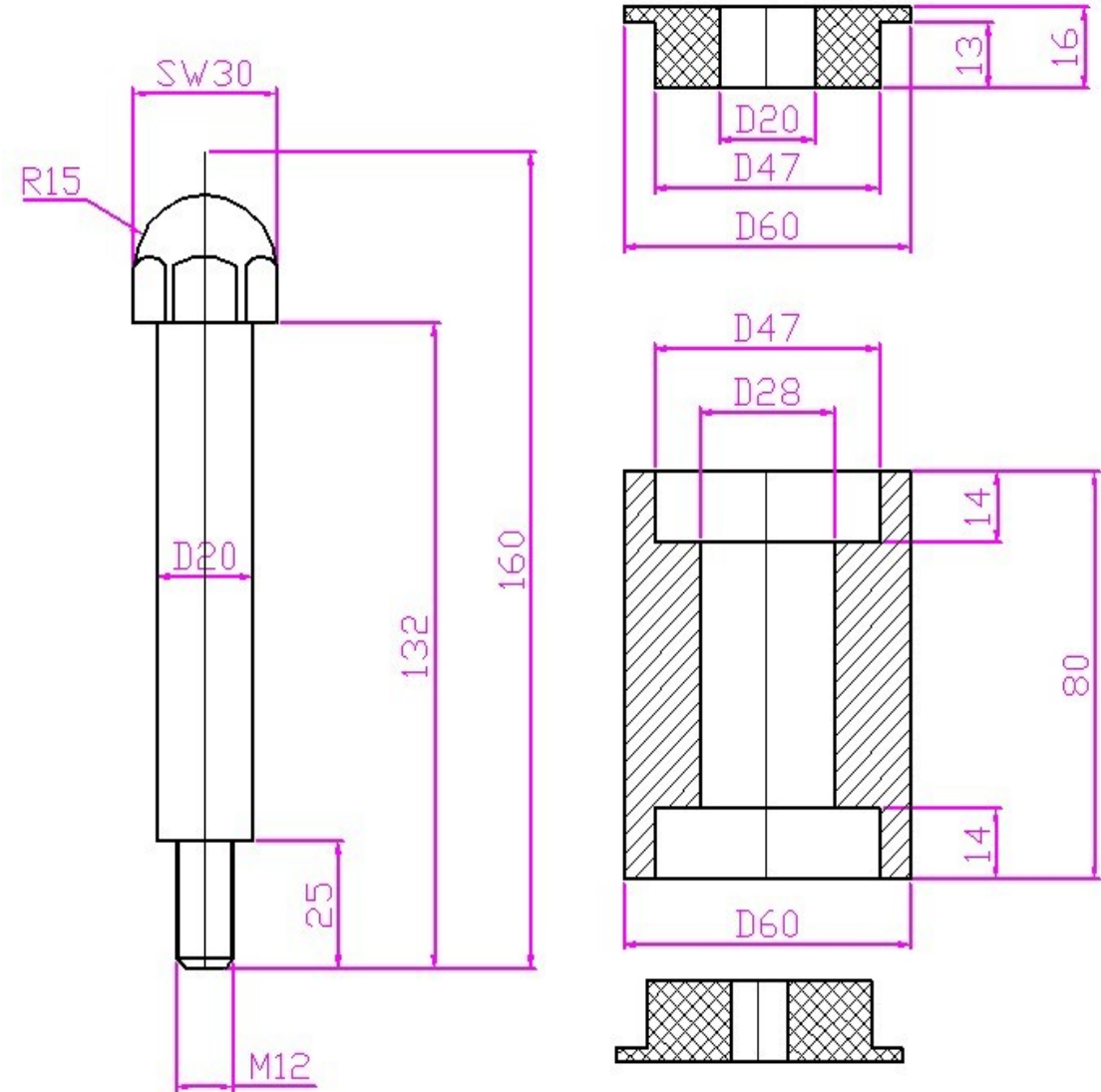

Gabelbrücken  
(Blechstärke 8mm)

oben

unten

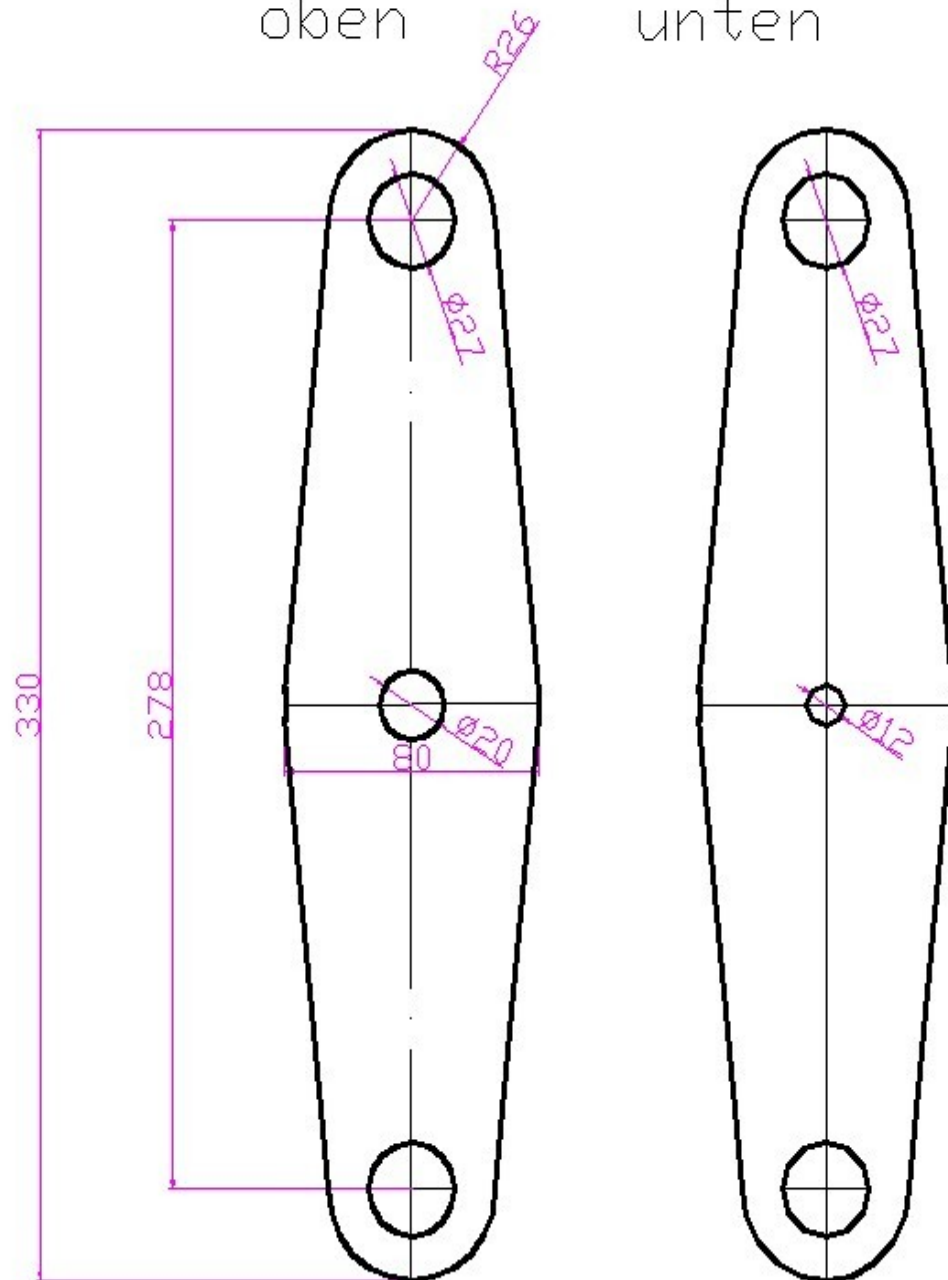

Gabelrohr D26,9  
x 2,6

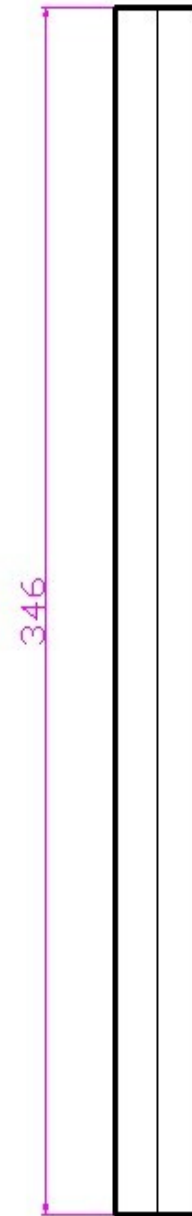

Seltenholme (60 x 30 x 2)

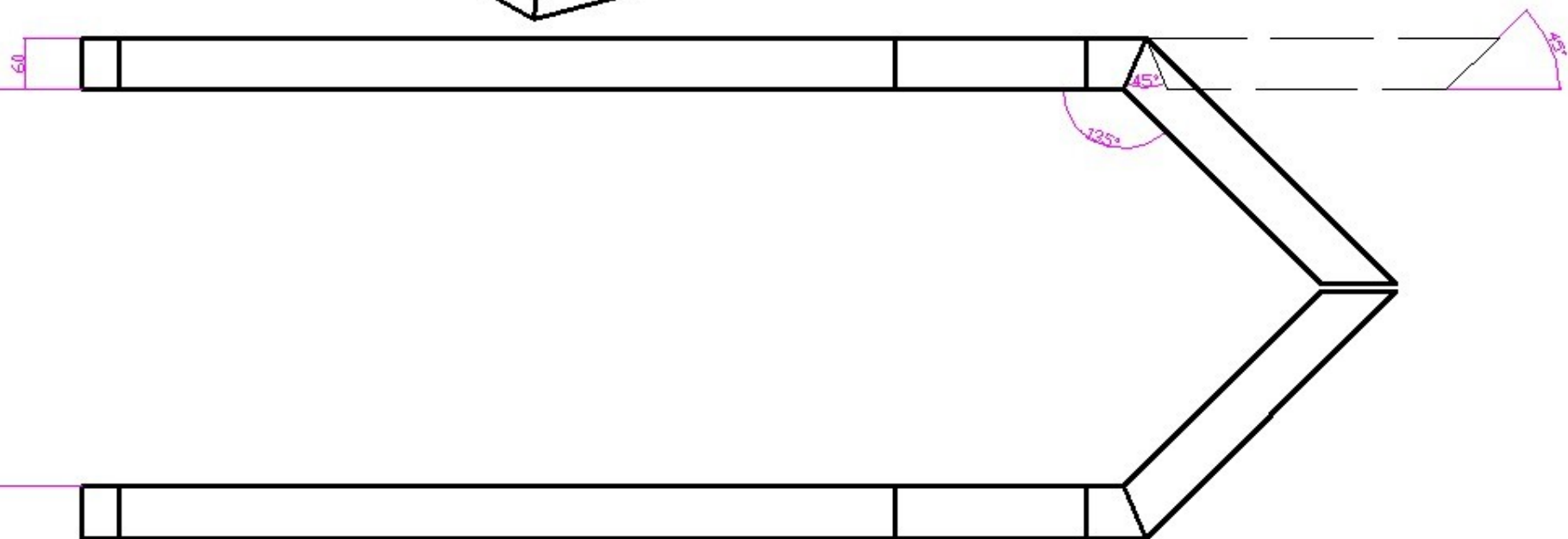
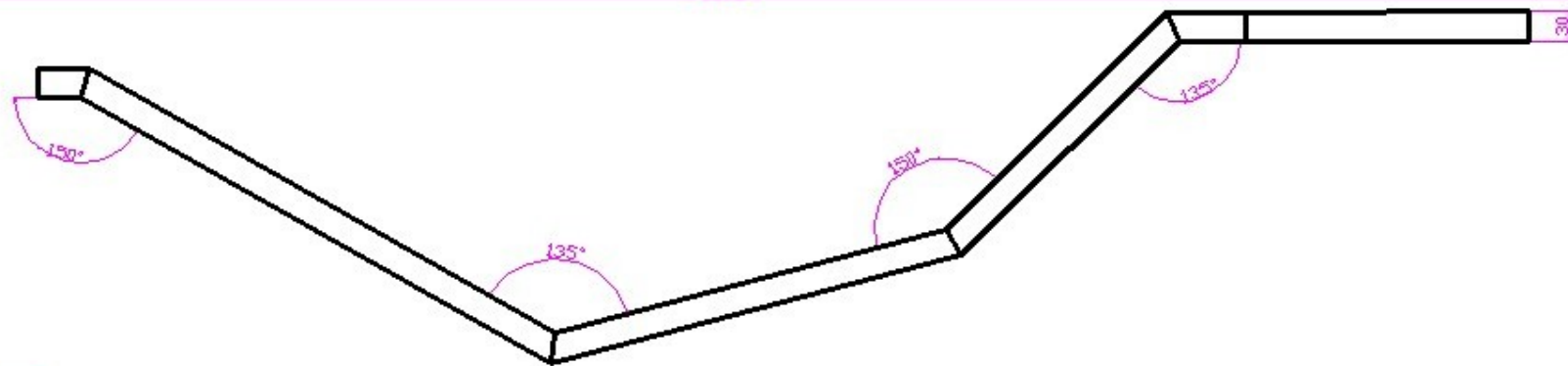
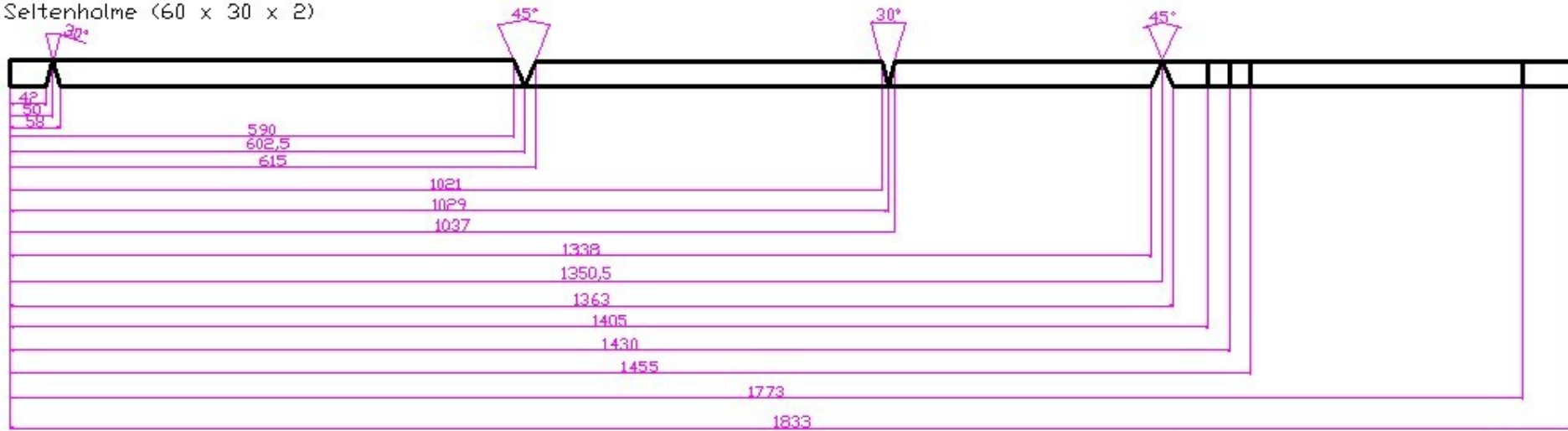

Die Breite entsprechend den Körpermaßen wählen!

# 2x Vorderachshalter (Blechstärke 8mm)

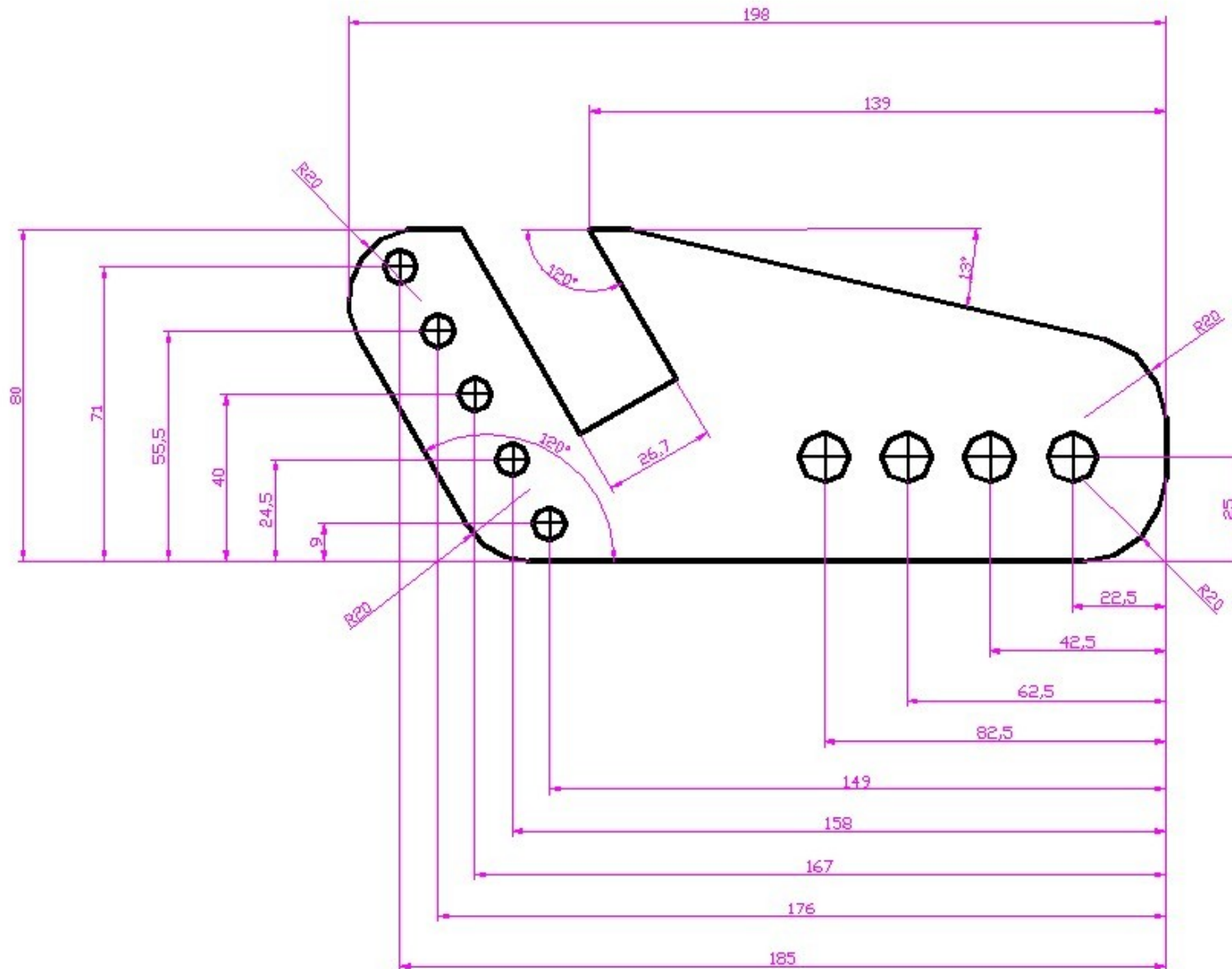

# Hinterachse (Rohr 48,3 x 2,6) mit Steckbuchsen und Radbolzen

